



CONFIDENTIAL

MULTI VTM **Heat Recovery Unit** **SERVICE MANUAL** **(Exploded View)**

MODEL : PRHR023 PRHR063 PRHR023A PRHR063A
PRHR033 PRHR083 PRHR033A PRHR083A
PRHR043 PRHR043A

CAUTION

Before Servicing the unit, read the safety precautions in General SVC manual.
Only for authorized service personnel.





Any reproduction, duplication, distribution (including by way of email, facsimile or other electronic means), publication, modification, copying or transmission of this Service Manual is **STRICTLY PROHIBITED** unless you have obtained the prior written consent of the LG Electronics entity from which you received this Service Manual. The material covered by this prohibition includes, without limitation, any text, graphics or logos in this Service Manual.

Copyright © 2017 - 2021 LG Electronics Inc. All rights reserved. Only training and service purposes.

TABLE OF CONTENTS



1. Safety Precautions	3
2. Specifications	11
3. Parts Functions	12
4. Dimensions	13
5. Piping Diagrams	15
6. Wiring Diagrams	16
7. Electric Characteristics	20
8. Exploded View	21

1. Precautions



	Read the precautions in this manual carefully before operating the unit.		This appliance is filled with flammable refrigerant (R32)
	This symbol indicates that the Operation Manual should be read carefully.		This symbol indicates that a service personnel should be handling this equipment with reference to the Installation Manual.

To prevent injury to the user or other people and property damage, the following instructions must be followed.





■ Incorrect operation due to ignoring instruction will cause harm or damage. The seriousness is classified by the following indications.









 WARNING	This symbol indicates the possibility of death or serious injury.
 CAUTION	This symbol indicates the possibility of injury or damage to properties only.





■ Meanings of symbols used in this manual are as shown below.





	Be sure not to do.
	Be sure to follow the instruction.
	Dangerous Voltage



1.1 Safety Precautions in Repair



 WARNING	
The appliance shall be stored so as to prevent mechanical damage from occurring	
Any person who is involved with working on or breaking into a refrigerant circuit should hold a current valid certificate from an industry-accredited assessment authority, which authorises their competence to handle refrigerants safely in accordance with an industry recognised assessment specification. Servicing shall only be performed as recommended by the equipment manufacturer. Maintenance and repair requiring the assistance of other skilled personnel shall be carried out under the supervision of the person competent in the use of flammable refrigerants.	
Keep any required ventilation openings clear of obstruction	
• Compliance with national gas regulations shall be observed	



<ul style="list-style-type: none"> • The installation of pipe-work shall be kept to a minimum • When flared joints are reused indoors, the flare part shall be re-fabricated. • When mechanical connectors are reused indoors, sealing parts shall be renewed. 	
<ul style="list-style-type: none"> • Do not use means to accelerate the defrosting process or to clean, other than those recommended by the manufacturer. • Do not pierce or burn. • Be aware that refrigerants may not contain an odour. • Ducts connected to an appliance shall not contain an ignition source. • Two or more people must lift and transport the product. Avoid personal injury. • Periodic (more than once/year) cleaning of the dust or salt particles stuck on the heat exchanger by using water. • Dismantling the unit, treatment of the refrigerant oil and eventual parts should be done in accordance with local and national standards. 	
<ul style="list-style-type: none"> • Mechanical connections shall be accessible for maintenance purposes. • Ducts connected to an appliance shall not contain an ignition source. • The appliance shall be disconnected from its power source during service and when replacing parts. 	
<p>Pipe-work shall be protected from physical damage.</p>	
<p>Checks to the area Prior to beginning work on systems containing flammable refrigerants, safety checks are necessary to ensure that the risk of ignition is minimised. For repair to the refrigerating system, the following precautions shall be complied with prior to conducting work on the system.</p>	
<p>Work procedure Work shall be undertaken under a controlled procedure so as to minimise the risk of a flammable gas or vapour being present while the work is being performed.</p>	
<p>General work area All maintenance staff and others working in the local area shall be instructed on the nature of work being carried out. Work in confined spaces shall be avoided. The area around the workspace shall be sectioned off. Ensure that the conditions within the area have been made safe by control of flammable material.</p>	
<p>Checking for presence of refrigerant The area shall be checked with an appropriate refrigerant detector prior to and during work, to ensure the technician is aware of potentially flammable atmospheres. Ensure that the leak detection equipment being used is suitable for use with flammable refrigerants, i.e. non-sparking, adequately sealed or intrinsically safe.</p>	
<p>Presence of fire extinguisher If any hot work is to be conducted on the refrigeration equipment or any associated parts, appropriate fire extinguishing equipment shall be available to hand. Have a dry powder or CO2 fire extinguisher adjacent to the charging area.</p>	

<p>No ignition sources</p> <p>No person carrying out work in relation to a refrigeration system which involves exposing any pipe work that contains or has contained flammable refrigerant shall use any sources of ignition in such a manner that it may lead to the risk of fire or explosion. All possible ignition sources, including cigarette smoking, should be kept sufficiently far away from the site of installation, repairing, removing and disposal, during which flammable refrigerant can possibly be released to the surrounding space. Prior to work taking place, the area around the equipment is to be surveyed to make sure that there are no flammable hazards or ignition risks. "No Smoking" signs shall be displayed.</p>	
<p>Ventilated area</p> <p>Ensure that the area is in the open or that it is adequately ventilated before breaking into the system or conducting any hot work. A degree of ventilation shall continue during the period that the work is carried out. The ventilation should safely disperse any released refrigerant and preferably expel it externally into the atmosphere.</p>	
<p>Checks to the refrigeration equipment</p> <p>Where electrical components are being changed, they shall be fit for the purpose and to the correct specification. At all times the manufacturer's maintenance and service guidelines shall be followed. If in doubt consult the manufacturer's technical department for assistance.</p> <p>The following checks shall be applied to installations using flammable refrigerants:</p> <ul style="list-style-type: none"> - The actual refrigerant charge is in accordance with the room size within which the refrigerant containing parts are installed - The ventilation machinery and outlets are operating adequately and are not obstructed - If an indirect refrigerating circuit is being used, the secondary circuit shall be checked for the presence of refrigerant - Marking to the equipment continues to be visible and legible. Markings and signs that are illegible shall be corrected - Refrigeration pipe or components are installed in a position where they are unlikely to be exposed to any substance which may corrode refrigerant containing components, unless the components are constructed of materials which are inherently resistant to being corroded or are suitably protected against being so corroded. 	
<p>Checks to electrical devices</p> <p>Repair and maintenance to electrical components shall include initial safety checks and component inspection procedures. If a fault exists that could compromise safety, then no electrical supply shall be connected to the circuit until it is satisfactorily dealt with. If the fault cannot be corrected immediately but it is necessary to continue operation, an adequate temporary solution shall be used. This shall be reported to the owner of the equipment so all parties are advised.</p>	

<p>Repairs to sealed components</p> <p>During repairs to sealed components, all electrical supplies shall be disconnected from the equipment being worked upon prior to any removal of sealed covers, etc. If it is absolutely necessary to have an electrical supply to equipment during servicing, then a permanently operating form of leak detection shall be located at the most critical point to warn of a potentially hazardous situation. Particular attention shall be paid to the following to ensure that by working on electrical components, the casing is not altered in such a way that the level of protection is affected. This shall include damage to cables, excessive number of connections, terminals not made to original specification, damage to seals, incorrect fitting of glands, etc. Ensure that apparatus is mounted securely. Ensure that seals or sealing materials have not degraded such that they no longer serve the purpose of preventing the ingress of flammable atmospheres. Replacement parts shall be in accordance with the manufacturer's specifications</p> <p>NOTE</p> <p>The use of silicon sealant can inhibit the effectiveness of some types of leak detection equipment. Intrinsically safe components do not have to be isolated prior to working on them.</p>	
<p>Repair to intrinsically safe components</p> <p>Do not apply any permanent inductive or capacitance loads to the circuit without ensuring that this will not exceed the permissible voltage and current permitted for the equipment in use. Intrinsically safe components are the only types that can be worked on while live in the presence of a flammable atmosphere. The test apparatus shall be at the correct rating. Replace components only with parts specified by the manufacturer. Other parts may result in the ignition of refrigerant in the atmosphere from a leak</p>	
<p>Cabling Check</p> <p>Cabling will not be subject to wear, corrosion, excessive pressure, vibration, sharp edges or any other adverse environmental effects. The check shall also take into account the effects of ageing or continual vibration from sources such as compressors or fans.</p>	
<p>Detection of flammable refrigerants</p> <p>Under no circumstances shall potential sources of ignition be used in the searching for or detection of refrigerant leaks. A halide torch (or any other detector using a naked flame) shall not be used.</p>	

<p>Leak detection methods</p> <p>The following leak detection methods are deemed acceptable for systems containing flammable refrigerants. Electronic leak detectors shall be used to detect flammable refrigerants, but the sensitivity may not be adequate, or may need re-calibration. (Detection equipment shall be calibrated in a refrigerant-free area.)</p> <p>Ensure that the detector is not a potential source of ignition and is suitable for the refrigerant used. Leak detection equipment shall be set at a percentage of the LFL of the refrigerant and shall be calibrated to the refrigerant employed and the appropriate percentage of gas (25 % maximum) is confirmed. Leak detection fluids are suitable for use with most refrigerants but the use of detergents containing chlorine shall be avoided as the chlorine may react with the refrigerant and corrode the copper pipe-work. If a leak is suspected, all naked flames shall be removed/extinguished. If a leakage of refrigerant is found which requires brazing, all of the refrigerant shall be recovered from the system, or isolated (by means of shut off valves) in a part of the system remote from the leak. Oxygen free nitrogen (OFN) shall then be purged through the system both before and during the brazing process.</p>	
<p>Removal and evacuation</p> <p>When breaking into the refrigerant circuit to make repairs – or for any other purpose - conventional procedures shall be used. However, it is important that best practice is followed since flammability is a consideration. The following procedure shall be adhered to:</p> <ul style="list-style-type: none"> - Remove refrigerant - Purge the circuit with inert gas - Evacuate - Purge again with inert gas - Open the circuit by cutting or brazing. <p>The refrigerant charge shall be recovered into the correct recovery cylinders. The system shall be “flushed” with OFN to render the unit safe. This process may need to be repeated several times. Compressed air or oxygen shall not be used for this task. Flushing shall be achieved by breaking the vacuum in the system with OFN and continuing to fill until the working pressure is achieved, then venting to atmosphere, and finally pulling down to a vacuum. This process shall be repeated until no refrigerant is within the system. When the final OFN charge is used, the system shall be vented down to atmospheric pressure to enable work to take place. This operation is absolutely vital if brazing operations on the pipe-work are to take place. Ensure that the outlet for the vacuum pump is not close to any ignition sources and there is ventilation available.</p>	

<p>Charging procedures</p> <p>In addition to conventional charging procedures, the following requirements shall be followed.</p> <ul style="list-style-type: none"> - Ensure that contamination of different refrigerants does not occur when using charging equipment. Hoses or lines shall be as short as possible to minimise the amount of refrigerant contained in them. - Cylinders shall be kept upright. - Ensure that the refrigeration system is earthed prior to charging the system with refrigerant. - Label the system when charging is complete (if not already). - Extreme care shall be taken not to overfill the refrigeration system. Prior to recharging the system it shall be pressure tested with OFN. The system shall be leak tested on completion of charging but prior to commissioning. A follow up leak test shall be carried out prior to leaving the site. 	
<p>Decommissioning</p> <p>Before carrying out this procedure, it is essential that the technician is completely familiar with the equipment and all its detail. It is recommended good practice that all refrigerants are recovered safely. Prior to the task being carried out, an oil and refrigerant sample shall be taken in case analysis is required prior to re-use of reclaimed refrigerant. It is essential that electrical power is available before the task is commenced.</p> <ol style="list-style-type: none"> a) Become familiar with the equipment and its operation. b) Isolate system electrically. c) Before attempting the procedure ensure that: <ul style="list-style-type: none"> • mechanical handling equipment is available, if required, for handling refrigerant cylinders; • all personal protective equipment is available and being used correctly; • the recovery process is supervised at all times by a competent person; • recovery equipment and cylinders conform to the appropriate standards. d) Pump down refrigerant system, if possible. e) If a vacuum is not possible, make a manifold so that refrigerant can be removed from various parts of the system. f) Make sure that cylinder is situated on the scales before recovery takes place. g) Start the recovery machine and operate in accordance with manufacturer's instructions. h) Do not overfill cylinders. (No more than 80 % volume liquid charge). i) Do not exceed the maximum working pressure of the cylinder, even temporarily. j) When the cylinders have been filled correctly and the process completed, make sure that the cylinders and the equipment are removed from site promptly and all isolation valves on the equipment are closed off. k) Recovered refrigerant shall not be charged into another refrigeration system unless it has been cleaned and checked. 	

<p>Labelling Equipment shall be labelled stating that it has been de-commissioned and emptied of refrigerant. The label shall be dated and signed. Ensure that there are labels on the equipment stating the equipment contains flammable refrigerant.</p>	
<p>Recovery When removing refrigerant from a system, either for servicing or decommissioning, it is recommended good practice that all refrigerants are removed safely. When transferring refrigerant into cylinders, ensure that only appropriate refrigerant recovery cylinders are employed. Ensure that the correct number of cylinders for holding the total system charge are available. All cylinders to be used are designated for the recovered refrigerant and labelled for that refrigerant (i.e. special cylinders for the recovery of refrigerant). Cylinders shall be complete with pressure relief valve and associated shut-off valves in good working order. Empty recovery cylinders are evacuated and, if possible, cooled before recovery occurs. The recovery equipment shall be in good working order with a set of instructions concerning the equipment that is at hand and shall be suitable for the recovery of flammable refrigerants. In addition, a set of calibrated weighing scales shall be available and in good working order. Hoses shall be complete with leak-free disconnect couplings and in good condition. Before using the recovery machine, check that it is in satisfactory working order, has been properly maintained and that any associated electrical components are sealed to prevent ignition in the event of a refrigerant release. Consult manufacturer if in doubt. The recovered refrigerant shall be returned to the refrigerant supplier in the correct recovery cylinder, and the relevant Waste Transfer Note arranged. Do not mix refrigerants in recovery units and especially not in cylinders. If compressors or compressor oils are to be removed, ensure that they have been evacuated to an acceptable level to make certain that flammable refrigerant does not remain within the lubricant. The evacuation process shall be carried out prior to returning the compressor to the suppliers. Only electric heating to the compressor body shall be employed to accelerate this process. When oil is drained from a system, it shall be carried out safely.</p>	

Minimum floor area (for R32)

- The appliance shall be installed, operated and stored in a room with a floor area larger than the minimum area.
- Use the graph of table to determine the minimum area.

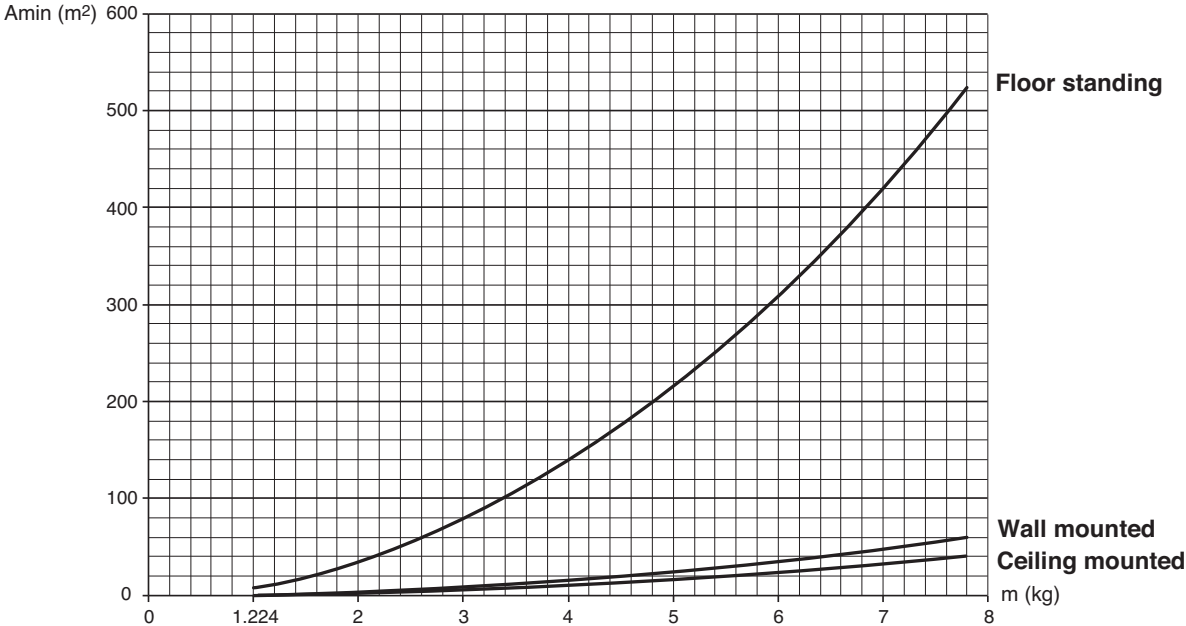

- m : Total refrigerant amount in the system
- Total refrigerant amount : factory refrigerant charge + additional refrigerant amount
- Amin : minimum area for installation

Floor location		Floor location		Wall mounted		Wall mounted		Ceiling Mounted		Ceiling Mounted	
m (kg)	Amin (m ²)	m (kg)	Amin (m ²)	m (kg)	Amin (m ²)	m (kg)	Amin (m ²)	m (kg)	Amin (m ²)	m (kg)	Amin (m ²)
< 1.224	-	4.6	181.56	< 1.224	-	4.6	20.17	< 1.224	-	4.6	13.50
1.224	12.9	4.8	197.70	1.224	1.43	4.8	21.97	1.224	0.956	4.8	14.70
1.4	16.82	5	214.51	1.4	1.87	5	23.83	1.4	1.25	5	15.96
1.6	21.97	5.2	232.02	1.6	2.44	5.2	25.78	1.6	1.63	5.2	17.26
1.8	27.80	5.4	250.21	1.8	3.09	5.4	27.80	1.8	2.07	5.4	18.61
2	34.32	5.6	269.09	2	3.81	5.6	29.90	2	2.55	5.6	20.01
2.2	41.53	5.8	288.65	2.2	4.61	5.8	32.07	2.2	3.09	5.8	21.47
2.4	49.42	6	308.90	2.4	5.49	6	34.32	2.4	3.68	6	22.98
2.6	58.00	6.2	329.84	2.6	6.44	6.2	36.65	2.6	4.31	6.2	24.53
2.8	67.27	6.4	351.46	2.8	7.47	6.4	39.05	2.8	5.00	6.4	26.14
3	77.22	6.6	373.77	3	8.58	6.6	41.53	3	5.74	6.6	27.80
3.2	87.86	6.8	396.76	3.2	9.76	6.8	44.08	3.2	6.54	6.8	29.51
3.4	99.19	7	420.45	3.4	11.02	7	46.72	3.4	7.38	7	31.27
3.6	111.20	7.2	444.81	3.6	12.36	7.2	49.42	3.6	8.27	7.2	33.09
3.8	123.90	7.4	469.87	3.8	13.77	7.4	52.21	3.8	9.22	7.4	34.95
4	137.29	7.6	495.61	4	15.25	7.6	55.07	4	10.21	7.6	36.86
4.2	151.36	7.8	522.04	4.2	16.82	7.8	58.00	4.2	11.26	7.8	38.83
4.4	166.12			4.4	18.46			4.4	12.36		

2. Specifications

2.1 HR Unit

Model		PRHR023 PRHR023A	PRHR033 PRHR033A	PRHR043 PRHR043A	
Max. Connectable No. of Indoor Units		16	24	32	
Max. Connectable No. of Indoor Units of a branch		8	8	8	
Net. Weight	kg	14.9	16.7	18.2	
	lbs	32.8	36.8	40.1	
Dimensions (WxHxD)	mm	786 X 218 X 657	786 X 218 X 657	786 X 218 X 657	
	Inch	30.9 X 8.6 X 25.9	30.9 X 8.6 X 25.9	30.9 X 8.6 X 25.9	
Casing		Galvanized steel plate			
Connecting Pipes	Indoor	Liquid Pipe [mm/inch]	Ø9.52[3/8] – Ø6.35[1/4]		
		Gas Pipe [mm/inch]	Ø15.88[5/8] – Ø12.7[1/2]		
	Outdoor	Liquid [mm/inch]	Ø9.52[3/8]	Ø12.7[1/2]	Ø15.88[5/8]
		Low Pressure [mm/inch]	Ø22.2[7/8]	Ø28.58[1 1/8]	Ø28.58[1 1/8]
		High Pressure [mm/inch]	Ø19.05[3/4]	Ø22.2[7/8]	Ø22.2[7/8]
Sound Absorbing Insulation Material		Polyethylene Foam			
Power Supply		1Ø, 220-240 V, 50 Hz / 1Ø, 220 V, 60 Hz 1Ø, 208/230 V, 60 Hz			

Model		PRHR063 PRHR063A	PRHR083 PRHR083A	
Max. Connectable No. of Indoor Units		48	64	
Max. Connectable No. of Indoor Units of a branch		8	8	
Net. Weight	kg	27.2	30.7	
	lbs	60	67.7	
Dimensions (WxHxD)	mm	1113 X 218 X 657	1113 X 218 X 657	
	Inch	43.8 X 8.6 X 25.9	43.8 X 8.6 X 25.9	
Casing		Galvanized steel plate		
Connecting Pipes	Indoor	Liquid Pipe [mm/inch]	Ø9.52[3/8] – Ø6.35[1/4]	
		Gas Pipe [mm/inch]	Ø15.88[5/8] – Ø12.7[1/2]	
	Outdoor	Liquid [mm/inch]	Ø15.88[5/8]	
		Low Pressure [mm/inch]	Ø28.58[1 1/8]	
		High Pressure [mm/inch]	Ø22.2[7/8]	
Sound Absorbing Insulation Material		Polyethylene Foam		
Power Supply		1Ø, 220-240 V, 50 Hz / 1Ø, 220 V, 60 Hz 1Ø, 208/230 V, 60 Hz		

Notes:

1. Voltage range : Units are suitable for use on electrical systems where voltage supplied to units terminals is not below or above listed range limits.
2. Maximum allowable voltage unbalance between phases is 2%

3. Parts Functions

3.1 Parts Functions

Parts name	Symbol	Major function
Low pressure gas pipe	LPGV	Pipe for low pressure gas
High pressure gas pipe	HPGV	Pipe for high pressure gas
Liquid pipe (to Outdoor unit)	LP(ODU)	Liquid pipe connected with outdoor unit
Liquid bypass valve	LBV	Prevent liquid charging
Solenoid assembly 1, 2	SOL1, 2	Control the path for heating or cooling
Liquid pipe (to Indoor unit)	LP(IDU)	Liquid pipe connected with indoor unit
Gas pipe	GSP	Gas pipe connected with indoor unit
Balancing valve	BLV	Control the pressure between High and Low pressure pipe during operation switching
Subcooling EEV	SCEEV	Control the subcooling

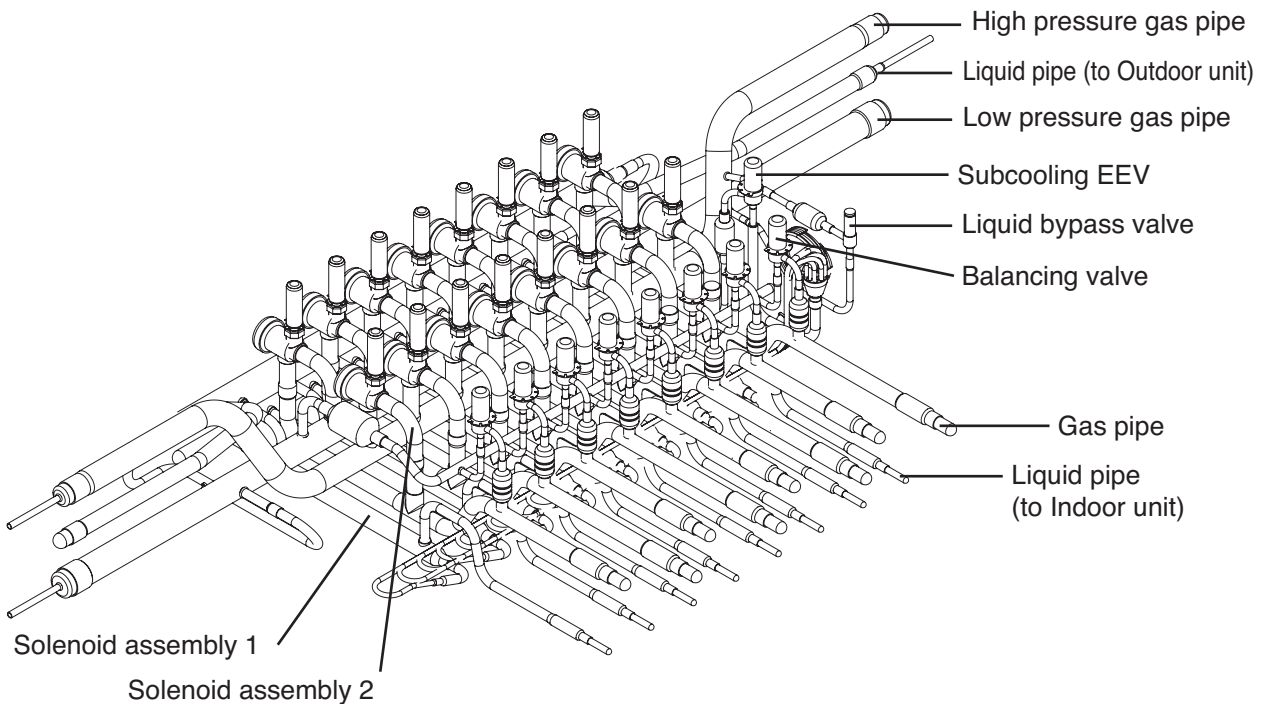

[PRHR083]

4. Dimensions

4.1 HR Units

HR Unit
PRHR023 / PRHR023A PRHR033 / PRHR033A PRHR043 / PRHR043A

The technical drawings include:

- Front View:** Shows a rectangular unit with a width of 500 mm and a height of 481 mm. The distance from the bottom edge to the top of the control panel is 311 mm, and the distance from the bottom edge to the top of the main body is 176 mm. The distance from the left edge to the center of the control panel is 125 mm. The distance from the left edge to the center of the main body is 486 mm. The distance from the right edge to the center of the main body is 150 mm.
- Side View:** Shows the unit's depth of 150 mm. Callouts 1, 2, and 3 point to the high, low, and liquid pressure gas pipes, respectively.
- Top View:** Shows the unit's width of 500 mm and depth of 150 mm. Callouts 4 and 5 point to the control panel and the liquid pipe to the indoor unit, respectively.
- Bottom View:** Shows the unit's depth of 150 mm and the location of the control panel and pipes. Callouts 4, 5, and 6 point to the control panel, the liquid pipe to the indoor unit, and the control box, respectively.

No.	Part Name	Description
6	Control box	-
5	Liquid pipe to Indoor unit	8- \varnothing 9.52 - \varnothing 6.35
4	Gas pipe to Indoor unit	8- \varnothing 15.88 - \varnothing 12.7
3	Low pressure gas pipe	2- \varnothing 28.58
2	Liquid pipe to Outdoor unit	2- \varnothing 15.88
1	High pressure gas pipe	2- \varnothing 22.2

LG Electronics Inc. Changwon 2nd factory 84, Wanam-ro, Seongsan-gu, Changwon-si, Gyeongsangnam-do, KOREA

CHASSIS CODE:

LG Electronics

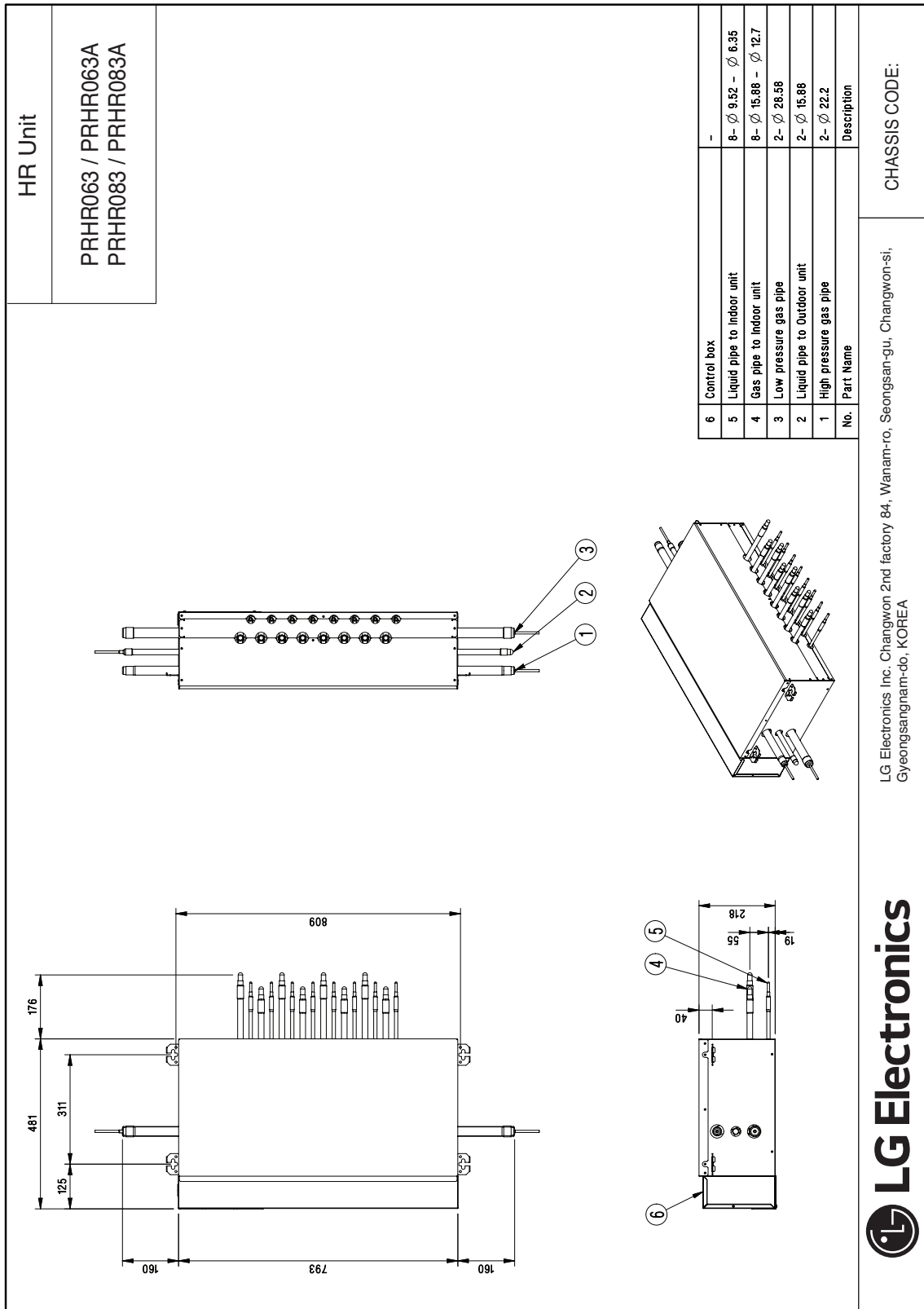

5. Piping Diagrams

5.1 HR Unit

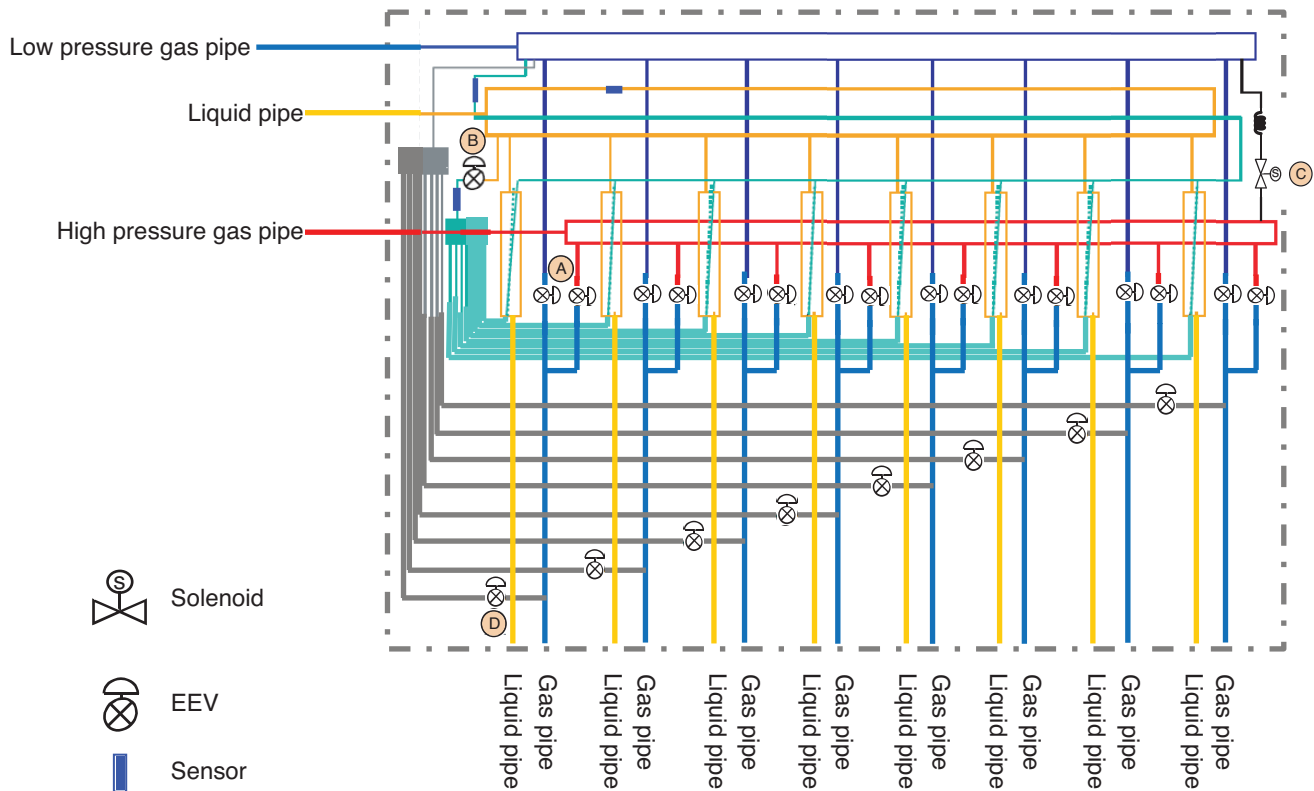

- Ⓐ : To be switched operation between cooling and heating by two valves
- Ⓑ : To be used decreasing noise according to sub-cooling of inlet and outlet of indoor unit (Simultaneous operation)
- Ⓒ : To prevent liquid charging between high pressure gas valve and HR unit at cooling mode
- Ⓓ : To be controlled the pressure between high and low pressure pipe during operation switching

6. Wiring Diagrams

6.1 HR Units

1) PRHR083, PRHR063

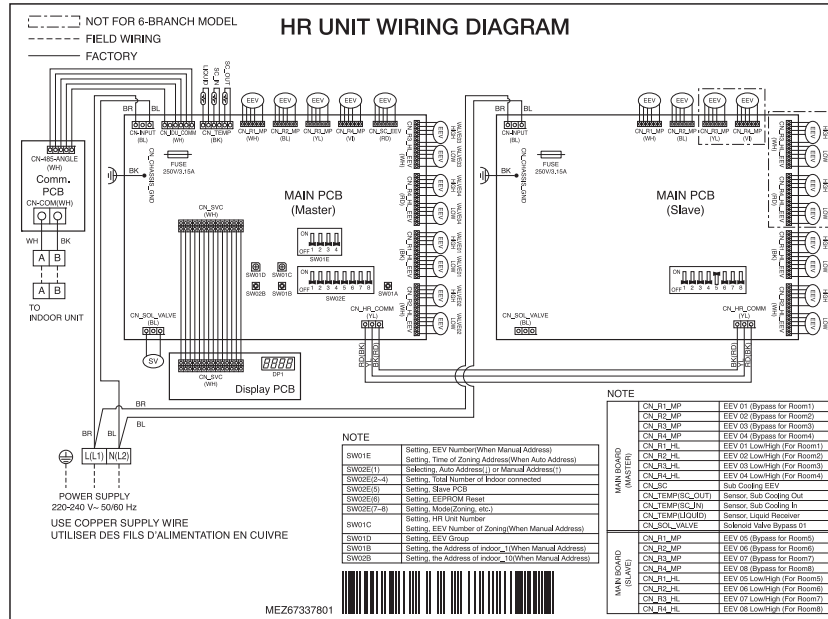

MAIN BOARD (MASTER)	CN_R1_MP	EEV 01 (Bypass for Room1)
	CN_R2_MP	EEV 02 (Bypass for Room2)
	CN_R3_MP	EEV 03 (Bypass for Room3)
	CN_R4_MP	EEV 04 (Bypass for Room4)
	CN_R1_HL	EEV 01 Low/High (For Room1)
	CN_R2_HL	EEV 02 Low/High (For Room2)
	CN_R3_HL	EEV 03 Low/High (For Room3)
	CN_R4_HL	EEV 04 Low/High (For Room4)
	CN_SC	Sub Cooling EEV
	CN_TEMP(SC_OUT)	Sensor, Sub Cooling Out
	CN_TEMP(SC_IN)	Sensor, Sub Cooling In
	CN_TEMP(LIQUID)	Sensor, Liquid Receiver
	CN_SOL_VALVE	Solenoid Valve Bypass 01
MAIN BOARD (SLAVE)	CN_R1_MP	EEV 05 (Bypass for Room5)
	CN_R2_MP	EEV 06 (Bypass for Room6)
	CN_R3_MP	EEV 07 (Bypass for Room7)
	CN_R4_MP	EEV 08 (Bypass for Room8)
	CN_R1_HL	EEV 05 Low/High (For Room5)
	CN_R2_HL	EEV 06 Low/High (For Room6)
	CN_R3_HL	EEV 07 Low/High (For Room7)
	CN_R4_HL	EEV 08 Low/High (For Room8)
SW01E	Setting, EEV Number(When Manual Address) Setting, Time of Zoning Address(When Auto Address)	
SW02E(1)	Selecting, Auto Address(↓) or Manual Address(↑)	
SW02E(2~4)	Setting, Total Number of Indoor connected	
SW02E(5)	Setting, Slave PCB	
SW02E(6)	Setting, EEPROM Reset	
SW02E(7~8)	Setting, Mode(Zoning, etc.)	
SW01C	Setting, HR Unit Number Setting, EEV Number of Zoning(When Manual Address)	
SW01D	Setting, EEV Group	
SW01B	Setting, the Address of indoor_1(When Manual Address)	
SW02B	Setting, the Address of indoor_10(When Manual Address)	

2) PRHR043, PRHR033, PRHR023

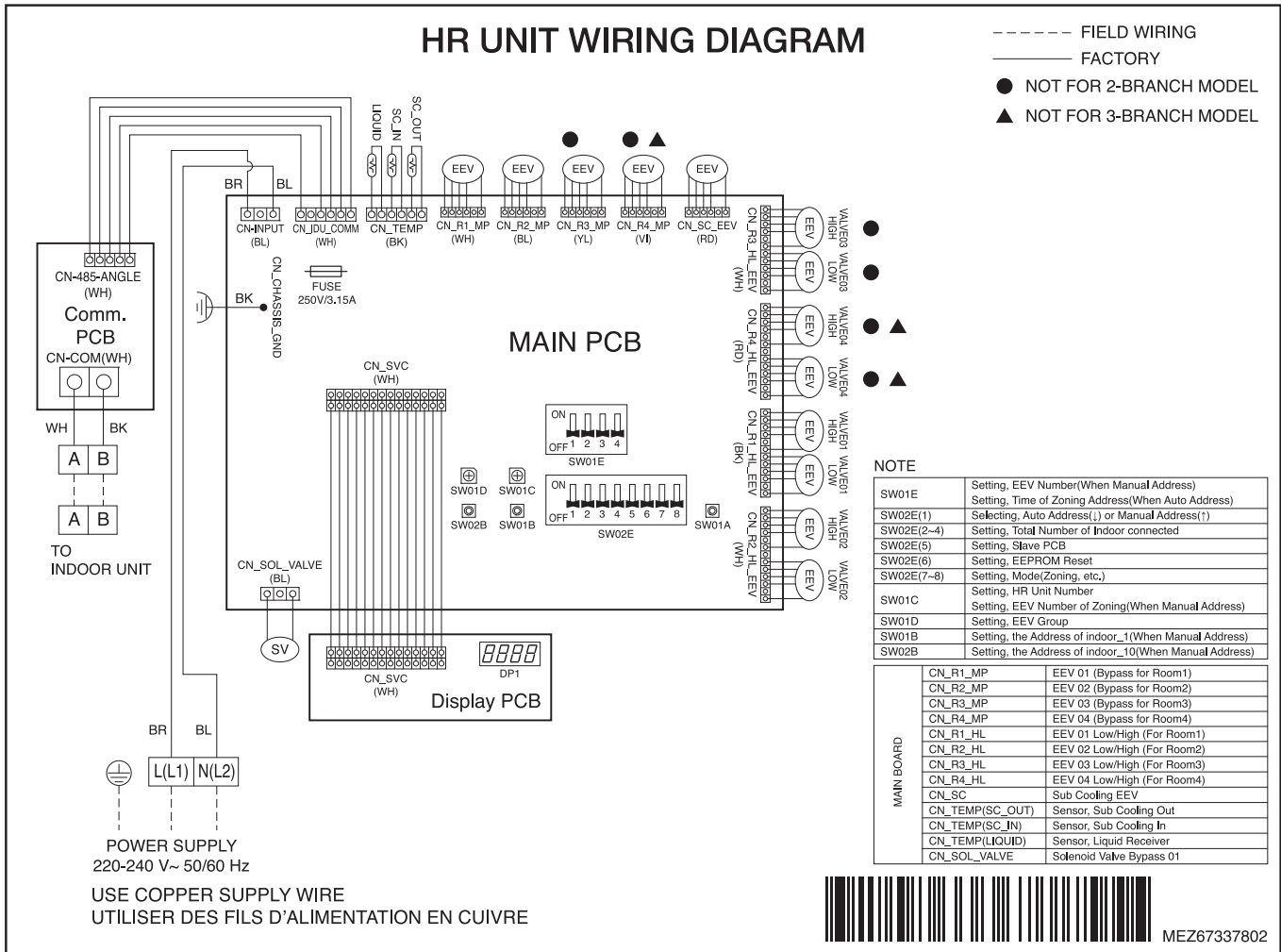

3) PRHR083A, PRHR063A

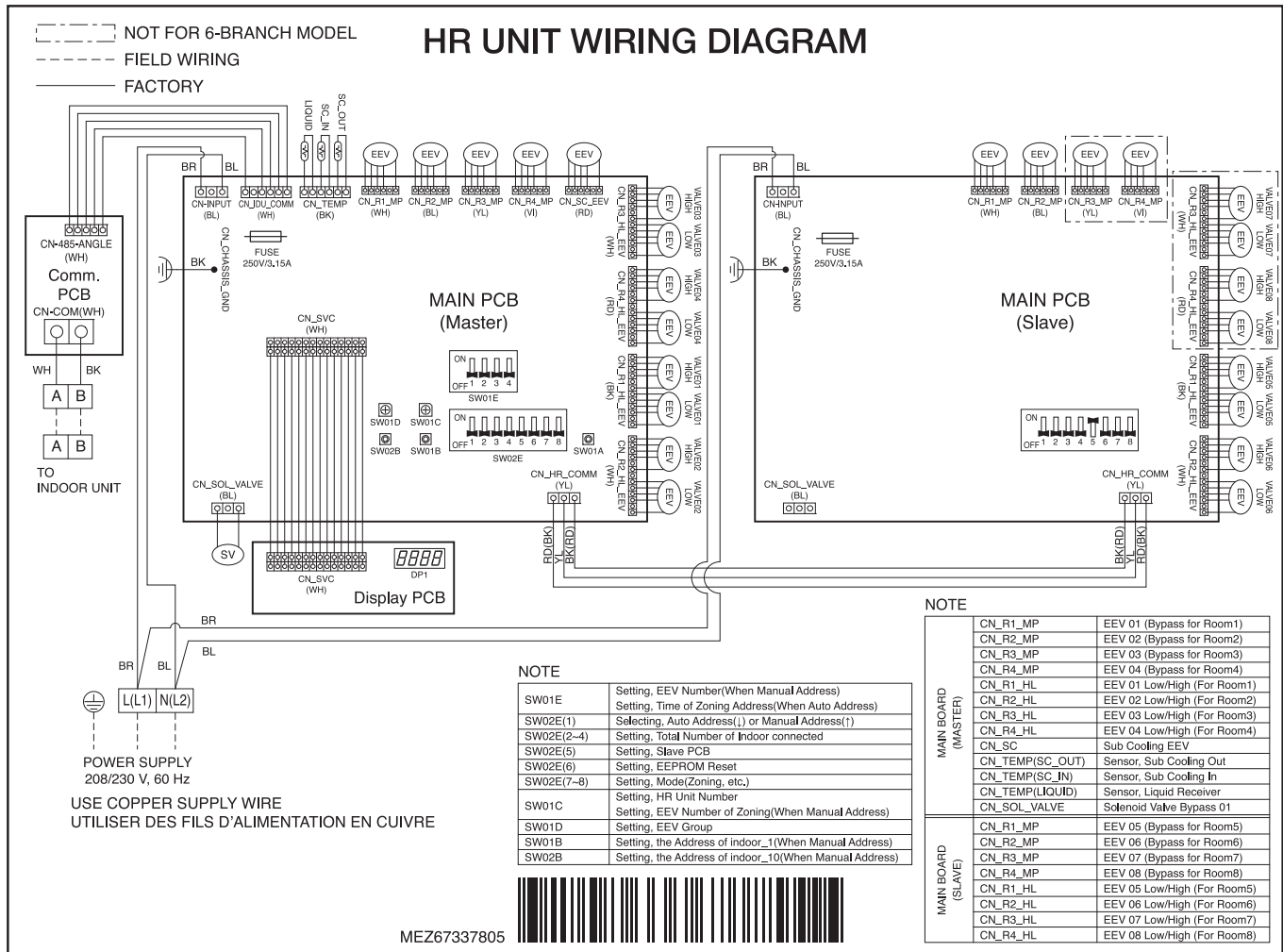

4) PRHR043A, PRHR033A, PRHR023A

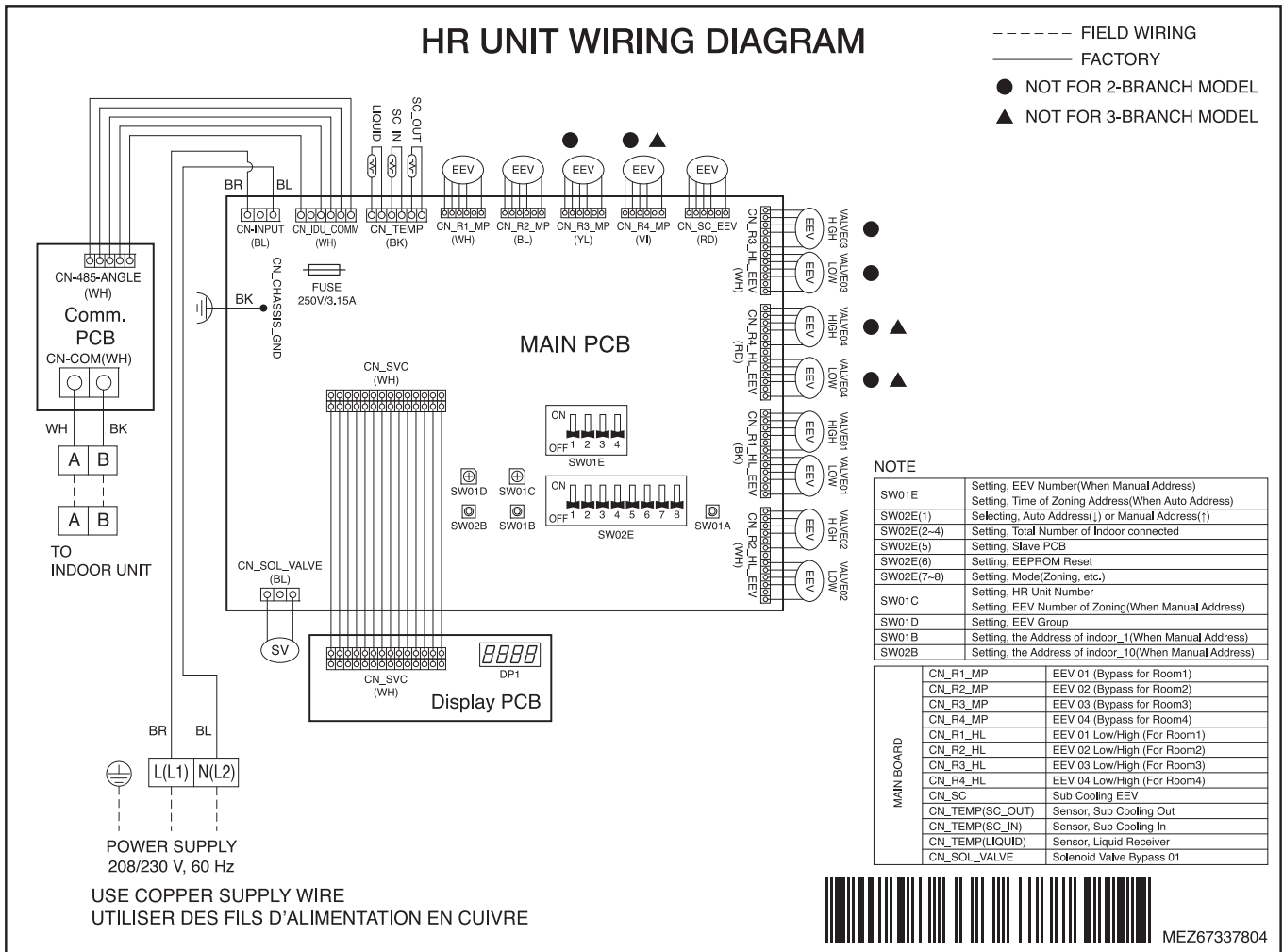

7. Electric Characteristics

7.1 HR Units

Units			Power Supply		IFM		Input(W)	
Model	Hz	Volts	MCA	MFA	kW	FLA	Cooling	Heating
PRHR023	50/60	220-240	0.17	15	-	-	39.8	37.2
PRHR033								
PRHR043								
PRHR063								
PRHR083								
PRHR023A	60	203/230	0.17	15	-	-	39.8	37.2
PRHR033A								
PRHR043A								
PRHR063A								
PRHR083A								

Symbols:

- MCA: Minimum Circuit Amperes (A)
- MFA : Maximum Fuse Amperes(see note 5)
- kW : Fan Motor Rated Output(kW)
- FLA : Full Load Amperes(A)
- IFM : Indoor Fan Motor

Note :

1. Voltage Range
Units are suitable for use on electrical system where voltage supplied to unit terminals is not below or above the listed range limits.
2. Maximum allowable voltage unbalance between phase is 2%.
3. MCA/MFA
MCA = 1.25 x FLA
MFA ≤ 4 x FLA
(Next lower standard fuse rating. Minimum 15A)
4. Select wire size based on the MCA.
5. Instead of fuse, use Circuit Breaker.

Warning : The appliance shall be disconnected from its power source during service and when replacing parts

8. Exploded View

8.1 HR Units

8.1.1 PRHR083 / PRHR083A

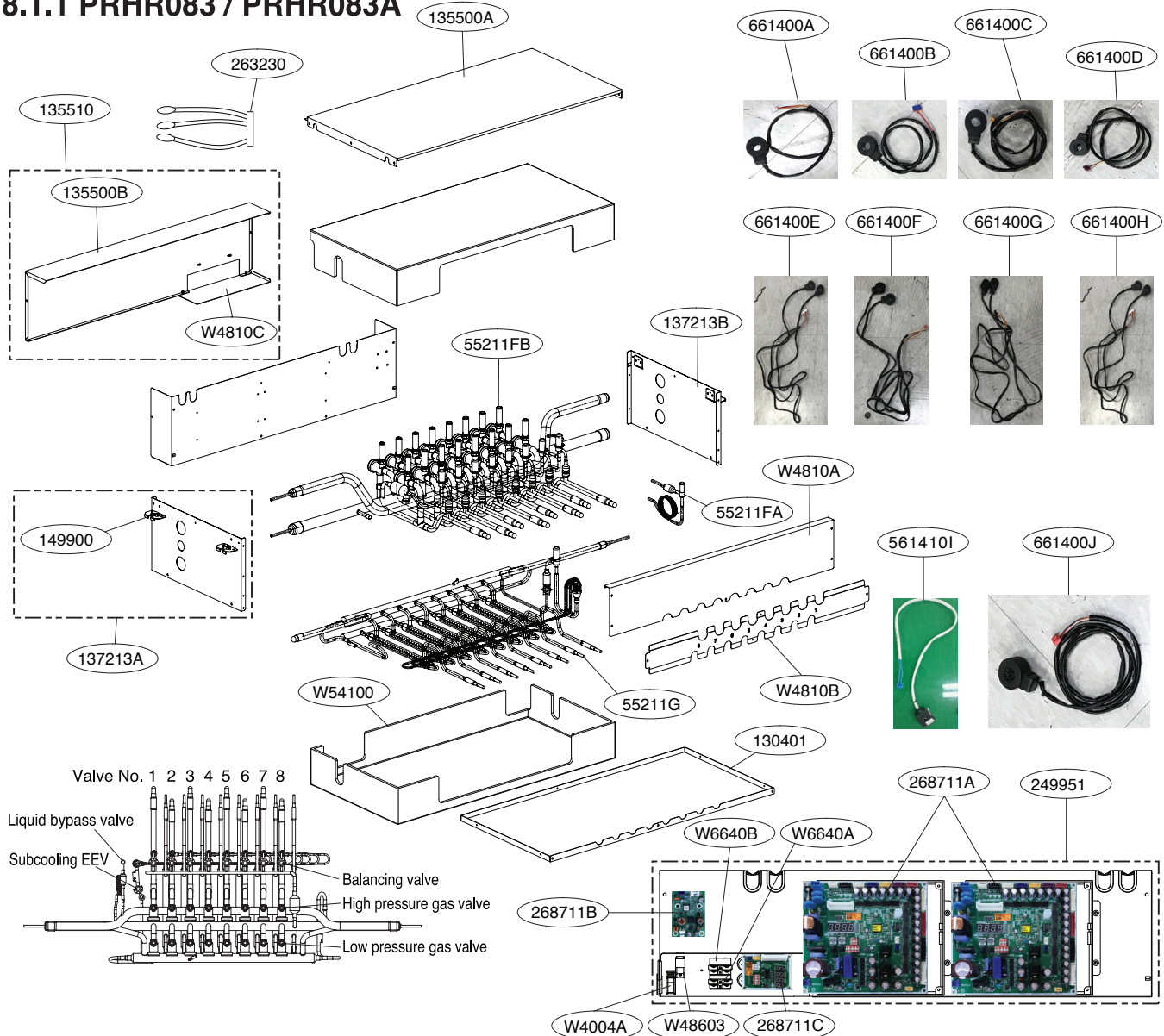

Valve No.	1	2	3	4	5	6	7	8
Balancing valve	661400A	661400B	661400C	661400D	661400A	661400B	661400C	661400D
High pressure valve	661400E	661400F	661400G	661400H	661400E	661400F	661400G	661400H
Low pressure valve								
Liquid bypass valve					561410I			
Subcooling valve					661400J			

Part	L/No.	Sensor Location	Remark
Thermistor 1	263230	SC out	heatproof PVC : blue
Thermistor 2		SC in	heatproof PVC : blue
Thermistor 3		Liquid	heatproof PVC : black

8.1.2 PRHR063 / PRHR063A

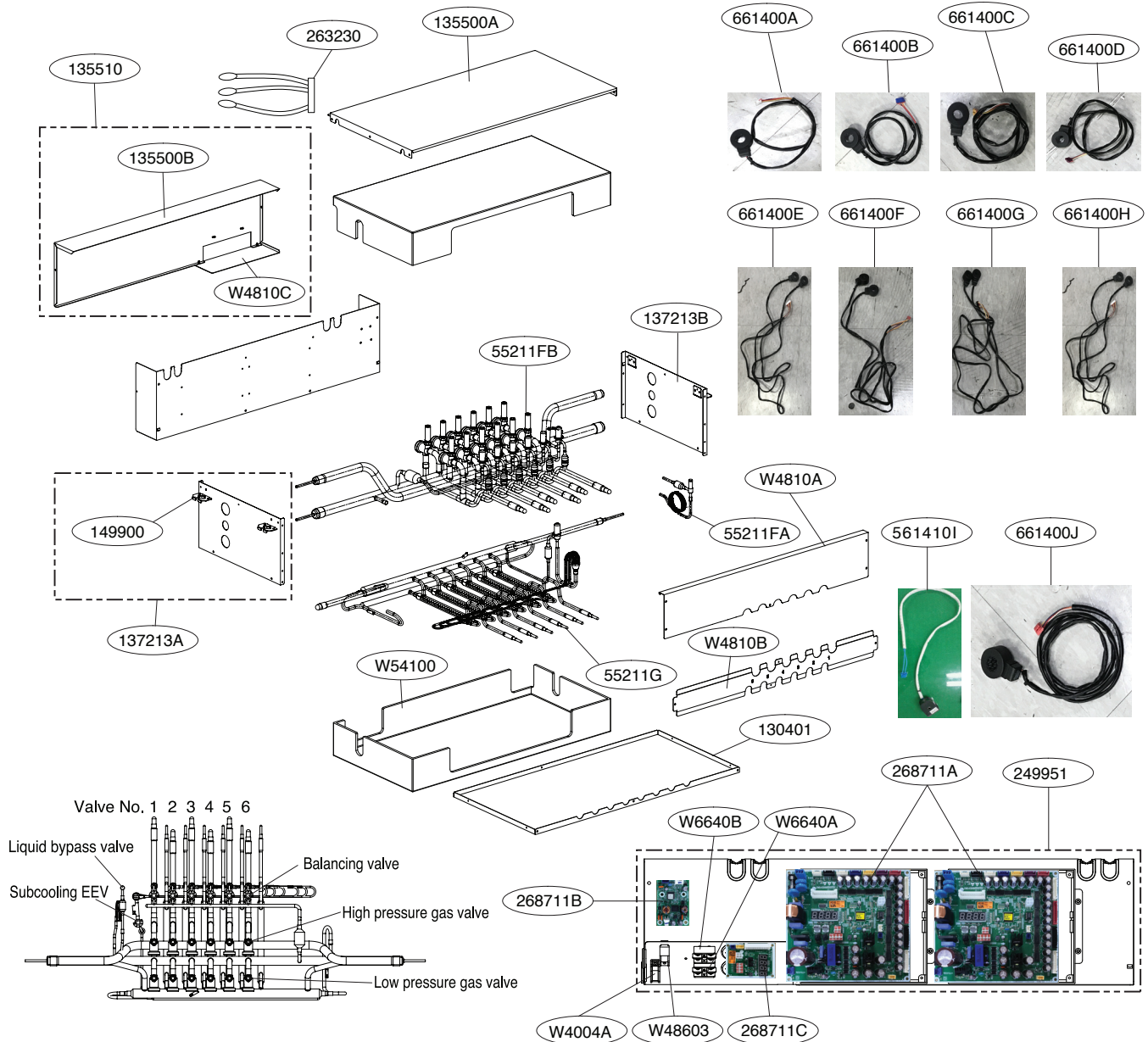

Valve No.	1	2	3	4	5	6
Balancing valve	661400A	661400B	661400C	661400D	661400A	661400B
High pressure valve	661400E	661400F	661400G	661400H	661400E	661400F
Low pressure valve						
Liquid bypass valve			561410I			
Subcooling valve			661400J			

Part	L/No.	Sensor Location	Remark
Thermistor 1	263230	SC out	heatproof PVC : blue
Thermistor 2		SC in	heatproof PVC : blue
Thermistor 3		Liquid	heatproof PVC : black

8.1.3 PRHR043 / PRHR043A

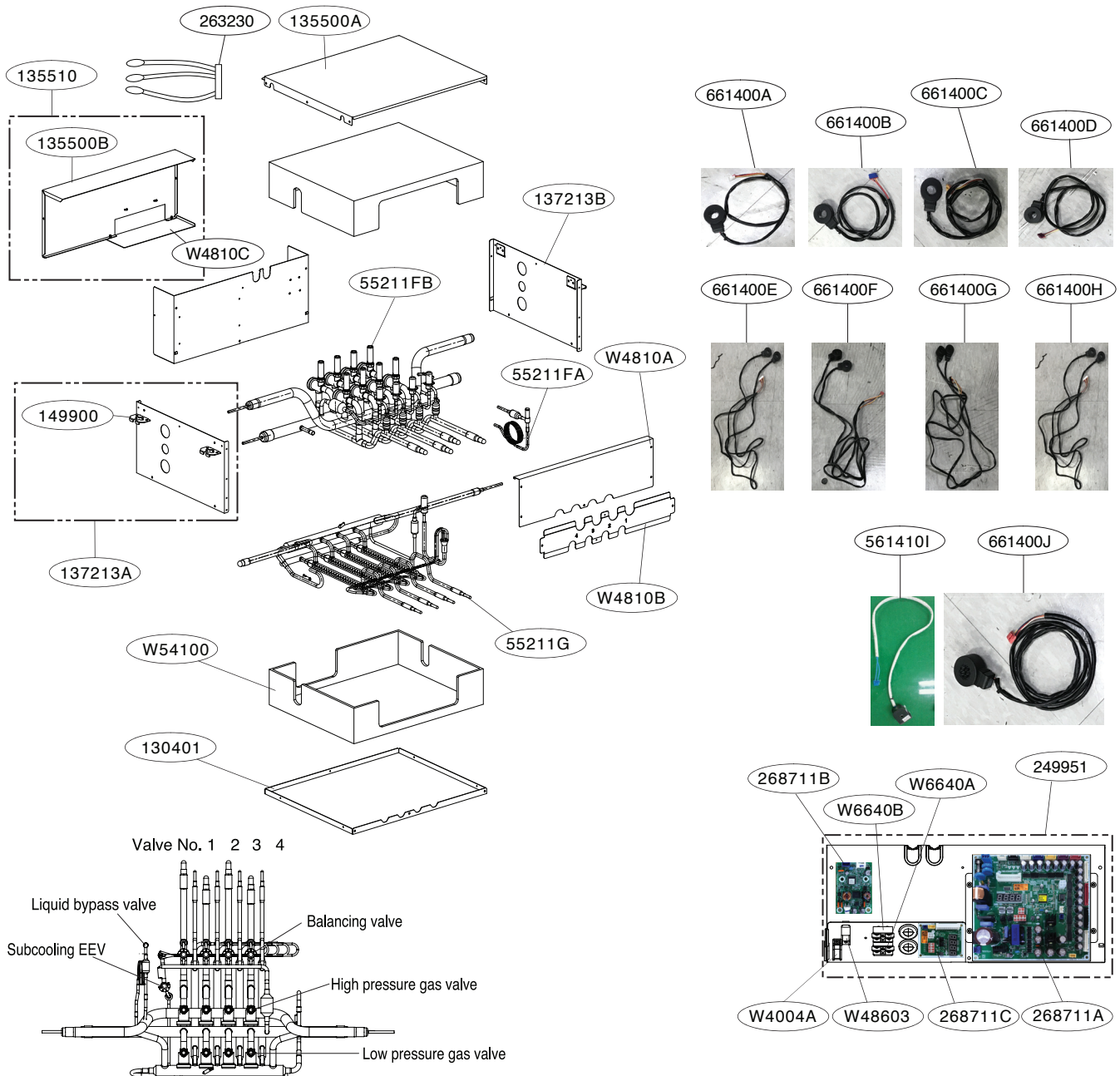

Valve No.	1	2	3	4
Balancing valve	661400A	661400B	661400C	661400D
High pressure valve	661400E	661400F	661400G	661400H
Low pressure valve				
Liquid bypass valve	561410I			
Subcooling valve	661400J			

Part	L/No.	Sensor Location	Remark
Thermistor 1	263230	SC out	heatproof PVC : blue
Thermistor 2		SC in	heatproof PVC : blue
Thermistor 3		Liquid	heatproof PVC : black

8.1.4 PRHR033 / PRHR033A

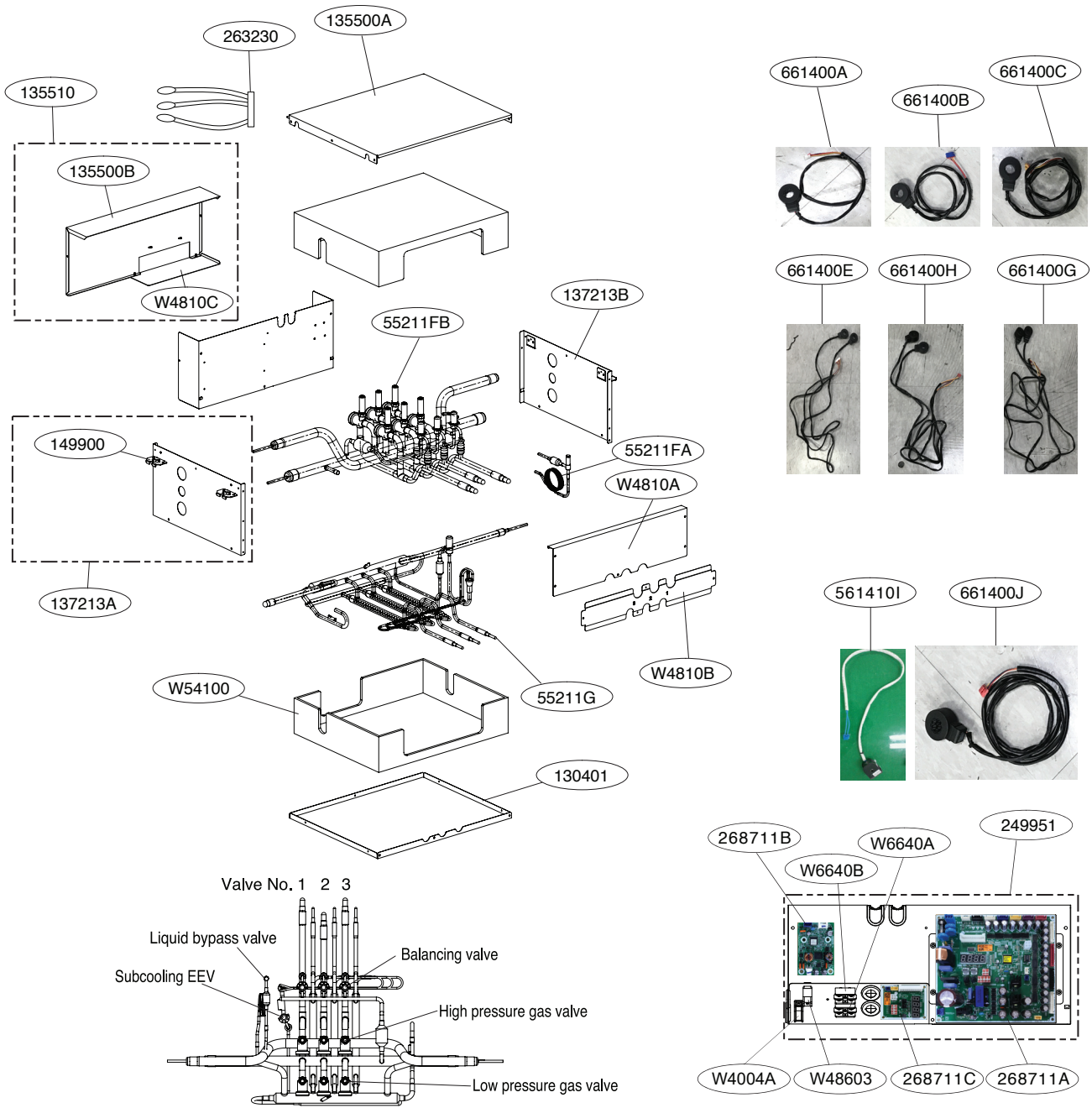

Valve No.	1	2	3
Balancing valve	661400A	661400B	661400C
High pressure valve	661400E	661400F	661400G
Low pressure valve			
Liquid bypass valve		561410I	
Subcooling valve		661400J	

Part	L/No.	Sensor Location	Remark
Thermistor 1	263230	SC out	heatproof PVC : blue
Thermistor 2		SC in	heatproof PVC : blue
Thermistor 3		Liquid	heatproof PVC : black

8.1.5 PRHR023 / PRHR023A

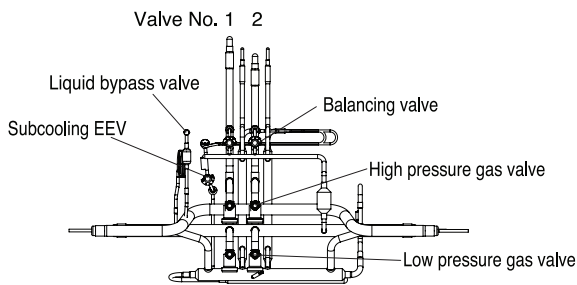
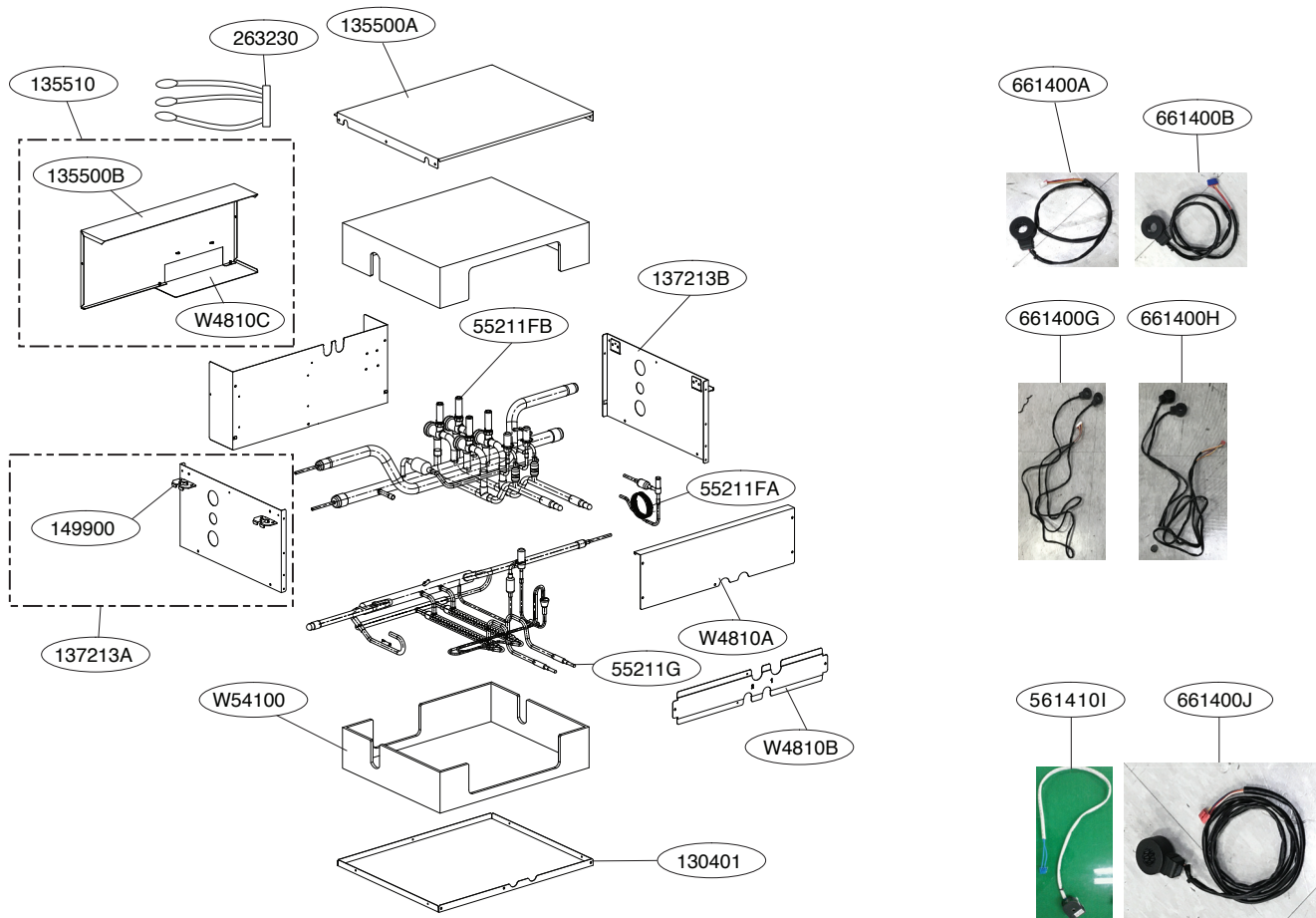

Valve No.	1	2
Balancing valve	661400A	661400B
High pressure valve	661400E	661400F
Low pressure valve		
Liquid bypass valve	561410I	
Subcooling valve	661400J	

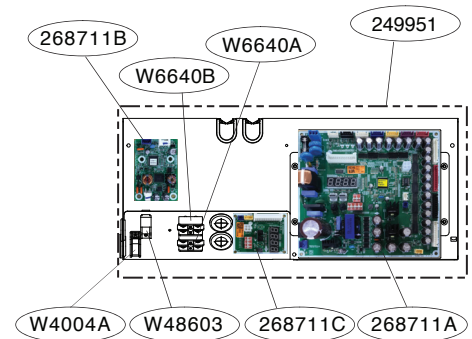

Part	L/No.	Sensor Location	Remark
Thermistor 1	263230	SC out	heatproof PVC : blue
Thermistor 2		SC in	heatproof PVC : blue
Thermistor 3		Liquid	heatproof PVC : black



P/NO : MFL67400012